

# VL0200

- IT Catenaccio a gomito automatico con fissaggio a vite dx/sx
- EN Automatic bolt, fixing by screws right-left application
- DE Automatische Stossriegel
- FR Verrou autobloquant, application droite - gauche. Fixation à vis.
- ES Pasador de palanca para atornillar

CODE	ARTICLE	PACK INFO	
<b>ZINCATO / GALVANIZED</b>			
<b>VL0200.310</b>	<b>42</b>	<b>12</b>	<b>7,7</b>

NOTE : Catenaccio per cancelli a due ante motorizzate, automatico con molla di richiamo in acciaio inox con ghiera di regolazione.  
Automatic bolt for double swing gates with adjustable stainless steel spring.  
Automatisch Stossriegel für Doppelflügeltore. Rückzugfeder in Edelstahl mit Einstellring.  
Verrou pour portails 2 vantaux motorisés fonctionnement automatique.  
Ressort de retour en acier inox avec embout de réglage.

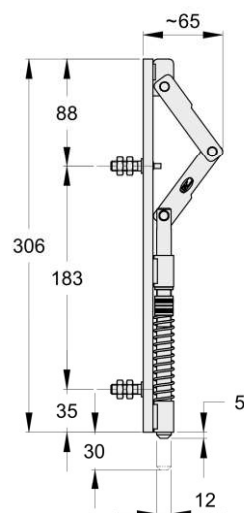

# VL0201

- IT Catenaccio a gomito ad avvitare
- EN Automatic bolt to fix
- DE Automatische Stossriegel zum Ausrauben
- FR Verrou autobloquant à fixer
- ES Pasador de palanca para atornillar

CODE	ARTICLE	PACK INFO	
<b>INOX / STAINLESS STEEL</b>			
<b>VL0201.270.i</b>	<b>1300</b>	<b>5</b>	<b>1,9</b>

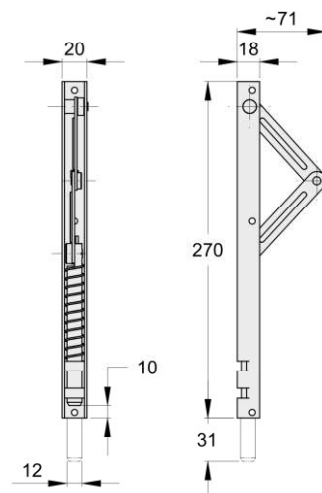

# VL0202

- IT Catenaccio automatico per cancelli a 2 ante ad avvitare
- EN Automatic bolt for double swing gates to fix
- DE Automatische Stossriegel
- FR Verrou automatique pour portails 2 vantaux à fixer
- ES Pasador automatico de palanca para 2 hojas

CODE	ARTICLE	PACK INFO	
<b>ZINCATO / GALVANIZED</b>			
<b>VL0202.180</b>	<b>44</b>	<b>6</b>	<b>2,5</b>

NOTE : In acciaio zincato e ottone / Galvanized steel and brass / Verzinkt und Messing / En acier galvanisé et laiton / De acero zincado y latón

